

**PLAN VIEW**

**NOTES:**

1. STATION REQUIRES 120 VOLT, 5 AMP DEDICATED CIRCUIT (PROVIDED BY OTHERS).
2. ONE (7/8") DIA HOLE LOCATED ON TOP OF STATION IS FOR AN ETHERNET CONNECTION (PROVIDED BY OTHERS) AND ONE (7/8") CONDUIT LOCATED ON TOP OF STATION IS FOR ELECTRICAL CONNECTION (PROVIDED BY OTHERS).
3. STATION IS FLOOR MOUNTED.
4. TOUCH CONTROL HEIGHT IS APPROXIMATELY 56" TO CENTER. **STATION IS NOT SUBJECT TO ADA REQUIREMENTS SINCE IT IS NOT USED BY THE PUBLIC.**
5. ROUGH OPENING IS 20" x 29" x 63".
6. STATION WEIGHT IS 227 LBS.

ETHERNET CONNECTION (BY OTHERS) TO AN ACTIVE JACK (INSIDE UNIT) ON THE SAME IT NETWORK AS THE PTS CONTROL CENTER

ELECTRICAL CONNECTION (BY OTHERS) SERVICE DISCONNECT FACTORY WIRED (INSIDE UNIT)

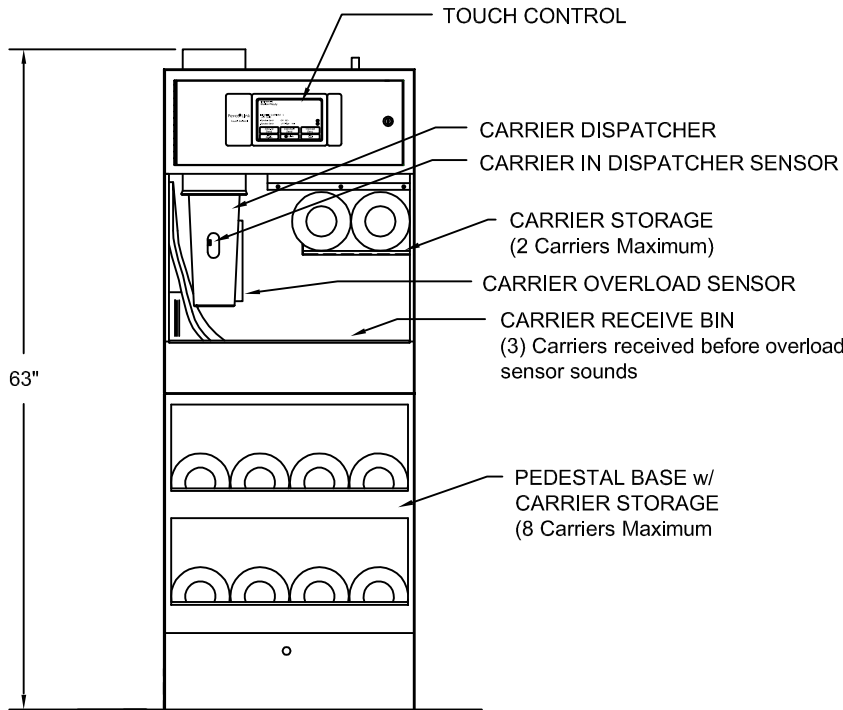

**FRONT VIEW**

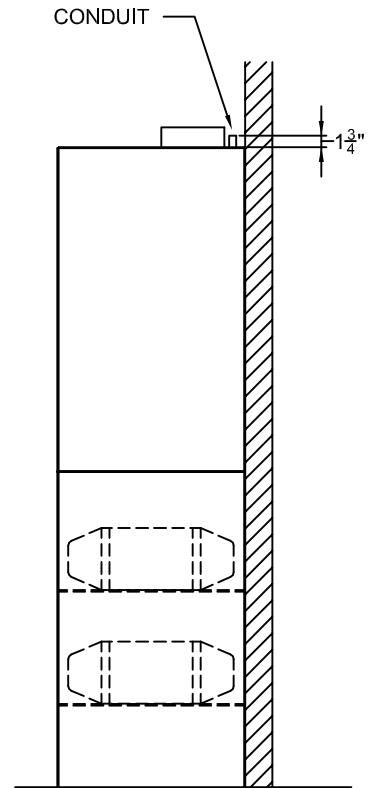

**SIDE VIEW**



1401 Tangier Drive  
 Baltimore, Maryland 21220  
 T 410.931.8800, F 410.931.4660  
 800.296.PEVCO (7382), www.pevco.com

**COMPACT STATION WITH CARRIER STORAGE PEDESTAL BASE (Ethernet Communications)**

SCALE	NONE	DATE
DRAWN	BK/SDW	02.24.13
REVISED	SDW	05.24.13
	-	-
DRAWING NUMBER	PEV200.34A	REVISION 1