

MULTI PORT SIDE  
UNIT DIMENSIONS

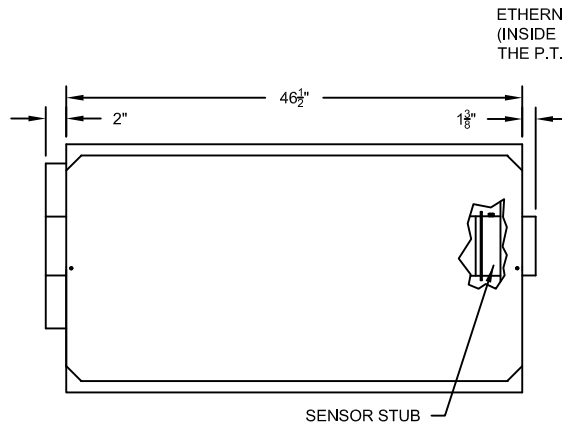

SIDE VIEW  
UNIT DIMENSIONS

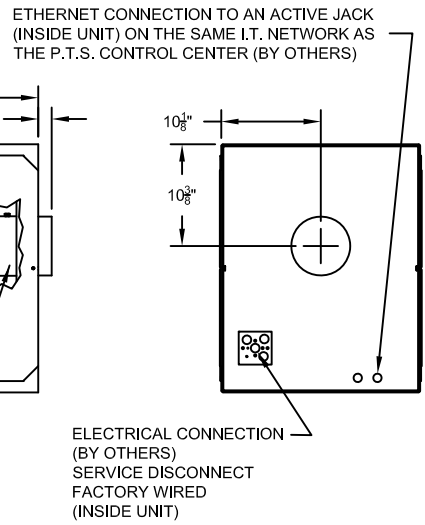

SINGLE PORT SIDE  
UNIT DIMENSIONS

NOTES:

1. MINIMUM OF 24" CLEARANCE ON ONE SIDE OF THE DIVERTER (FROM TOP OF THE DIVERTER TO THE FLOOR) IS REQUIRED FOR MAINTENANCE AND SERVICE ACCESS.
2. TWO 7/8" DIA. HOLES FOR COMMUNICATION CABLES, (PROVIDED BY OTHERS) ON SINGLE PORT SIDE. POWER INLET, ON SINGLE PORT SIDE.
3. DIVERTER REQUIRES 120 VOLT, 5 AMP DEDICATED CIRCUIT (PROVIDED BY OTHERS).
4. DIVERTER WEIGHT IS 155 LBS.

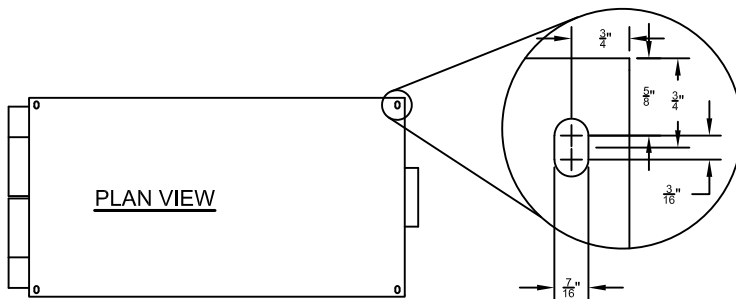

HANGER ROD LOTS  
4PL. TYP.

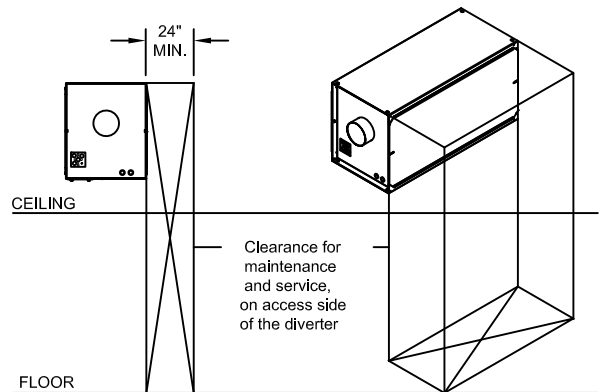

ACCESS CLEARANCE



1401 Tangier Drive  
Baltimore, Maryland 21220  
T 410.931.8800, F 410.931.4660  
800.296.PEVCO (7382), www.pevco.com

6 PORT DIVERTER  
(Ethernet Communications)

6" COMPUTERIZED PNEUMATIC TUBE SYSTEMS

SCALE	NONE	DATE
DRAWN	S.S.	01.31.23
REVISED	-	-
	-	-
DRAWING NUMBER	-	REVISION 0